

# MDT-122

## Man-Down Transmitter



## User's Guide

### 1. INTRODUCTION

MDT-122 is an automatic personal security transmitter. This micro-processor controlled transmitter is designed for use by guards in a prison, by security officers in an organization or institution, or by employees in a large industrial complex (as an industrial signaling device for safety). In areas that 1 person is not allowed to work alone, MDT-122 can be an excellent solution.

MDT-122 and the recommended compatible receiver **MCR-308** (or SCP-552 ER, PowerMax, Maestro-1600 or MAX-20W wireless devices) can be integrated in any alarm system.

MDT-122 is attached to the guard's pouch / holster.

The transmitter is activated in the following events (see fig. 2):

#### A. PANIC

When the guard needs help, he presses both buttons (pressing both buttons is required to prevent an accidental panic message transmission).

#### B. MANDOWN

When the guard falls down (automatic transmission when the unit is tilted down by more than 60°).

#### C. PULL-CORD

The pull-cord is attached strongly by a clip to the guard's belt on one side and is plugged into the transmitter by an easily detachable plastic pin on the other side. Pulling the cord or the unit away causes the plastic pin to be detached and to release an internal switch that activates an alarm transmission. This may happen when an attacker tries to draw the unit away from the guard or by the holder, in case of emergency and difficulty to press the twin buttons for alarm.

#### D. TEST

When the guard presses the left or right push-button, a test message is sent to the alarm system and the LED is lit.

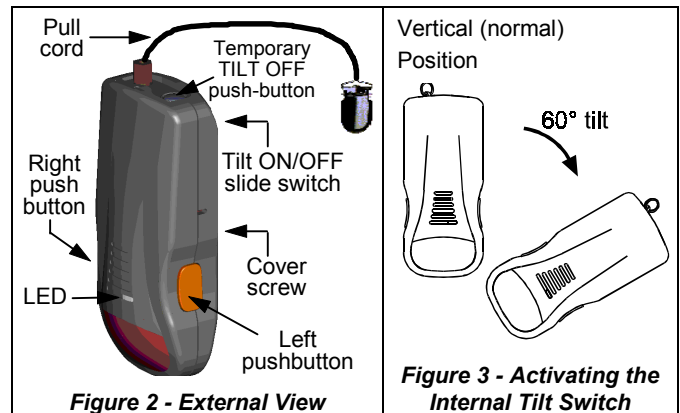

#### E. TAMPER EVENT

When the transmitter is opened by an unauthorized person.

When the transmitter is activated, an identifiable alert is transmitted to the associated receiver. As a result, a siren sounds, an automatic dialer calls predetermined addressees, etc., as desired, to provide the required help.

Tilt alarm restoration message is transmitted when the unit returns to its normal position (vertical) and when the tilt on/off switch is switched to OFF position.

The transmitter is not activated during the guard's regular daily activities (running, jumping, sitting, bending, removing clothes, going to bathroom and going off and on duty).

If the unit is laid down in horizontal position more than 60 seconds, while the tilt ON/OFF switch is in OFF position, when it is returned to vertical position 3 beeps are sounded, to remind the user to return the Tilt switch to ON position (Tilt switch reminder).

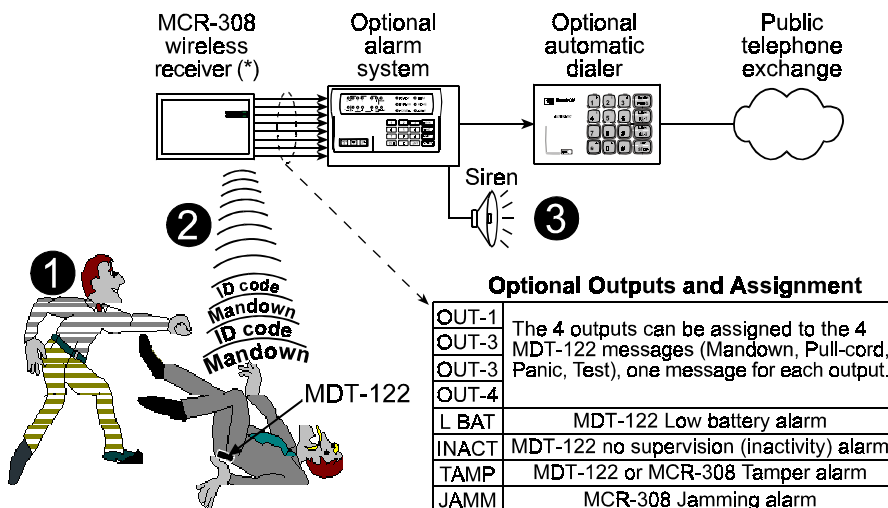

Figure 1 - Integration of MDT-122 in an Alarm System

**\* MCR-308 Outputs Expansion**

One MCR-308 is recommended for one MDT-122 transmitter, by using its 4 outputs for the 4 transmitter's messages.

The outputs number can be increased by connecting up to three MCX-8, 8-output expander modules, connected via a 4-wire expansion bus.

MCR-308 and three MCX-8 comprise 28 outputs, that are recommended for seven MDT-122 transmitters (4 outputs for every transmitter). More transmitters can also be used, when the distinction capability between transmitters/events is not important.

4-wire expansion bus	MCX-8 expander	8 outputs
	MCX-8 expander	8 outputs
	MCX-8 expander	8 outputs
	MCR-308 receiver	4 outputs

28 outputs are recommended for seven MDT-122 transmitters.

## 2. SPECIFICATIONS

**Transmission Type:** Radio Frequency (RF)  
**RF frequency (MHz):** 315, 418 or 433.92  
**Transmitter's ID Code:** 20-bit ID, 4-bit event ID  
**Modulation type:** pulse width modulation  
**Overall Message Length:** 36 bit  
**Alarm Messages:** Tilt activated, pull-cord disconnected, Panic alarm, Test, each with separate ID  
**Supervision:** Option for automatic reporting at 1-hour intervals  
**Power Source:** 3.6 V, Lithium battery, size 1/2 AA / 1.2 Ah, (Tadiran TL-2150 or equivalent.)  
**Current Consumption:** 15µA standby, 10mA (operation).  
**Battery Life:** 3-4 years in normal use

**Battery Supervision:** Battery test and reporting every hour.  
**Operating temperature:** 0°C to 49°C (32°F to 120°F)  
**Dimensions (H x W x D):** 120 x 52 x 36 mm (4-3/4 x 2-1/16 x 1-5/16 in.)  
 With Holster-3: 140 x 77 x 50 mm (5-7/16 x 3-1/16 x 1-15/16 in.)  
**Housing:** 3mm ABS plastic box, weather proof  
**Weight:** Man-down -138 g (4.9 Oz.), Holster-3 - 30 g (1.05 Oz.)  
**Color:** Body - dark gray, buttons - brown, pull cord - black  
**Compliance with Std.:** FCC Part 15, CE (ETS 300220, ETS 300683)  
**Accessories:** Light weight water-resistant carry pouch Holster-3.  
 Metal belt clip.  
 Pull-cord with pin and cloth clip.

## 3. FUNCTIONAL DESCRIPTION

### 3.1 Visual and Audible Warning Timing

A built-in tilt sensor activates the unit when the unit is tilted down by more than 60° (see figure 3). When the unit is activated, it enters a pre-alarm state for 15 seconds. This period enables the user to return the transmitter to the normal (vertical) position, to prevent an unintentional alarm transmission.

During this period an audible warning is sounded by the buzzer and a visual warning is indicated (by the internal LED). The buzzer's sound can be disabled by using an internal buzzer's switch (see table 1). Figure 4 presents the timing diagram.

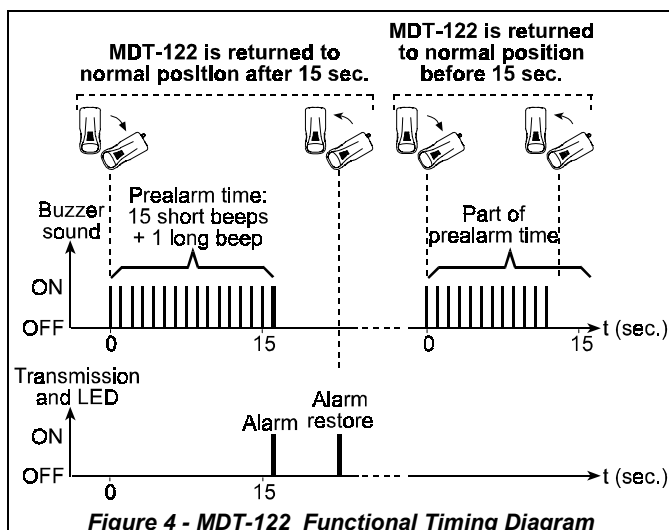

### 3.2 Low Battery Voltage Indication

The battery is automatically tested every hour, under load condition. If the battery voltage is low, "low battery" message is sent every transmission and whenever supervision message is sent (if enabled, see table 1).

In addition, when the battery voltage is low, the LED blinks while pressing the left or right push-button switch.

### 3.3 External Buttons Functions (see fig. 2)

#### A. Left or Right push-buttons

When the guard presses left or right push-button, a test message is sent to the alarm system or any other desired auxiliary function is performed, according to the software definitions.

When left and right push-buttons are pressed, panic alarm is transmitted.

#### B. Tilt ON-OFF Slide Switch

By using this switch, the user can disable the tilt sensor function (this is necessary when a guard goes off duty or performs such activities that can activate the transmitter and create a false alarm). When the unit is delivered from the factory, the switch is in OFF position.

#### C. Temp Tilt Off Push-Button Switch

The push-button is located at the top of the unit. It is used for temporary disabling (5 minutes) of the tilt sensor function, when it is desired. To re-enable tilt function before the 5 minutes delay expires, the tilt ON-OFF slide switch should be switched to OFF position and then to ON again.

### 3.4 Pull-Cord Function (see par. 1C)

### 3.5 Internal DIP Switches Functions

Table 1 - Internal DIP Switches Functions

Switch	Description	Default
1	Buzzer ON/OFF	ON
2	Pull-cord option	ON
3	Supervision ON/OFF	OFF
4	Supervision message type (*)	OFF (slow)
5	(For future use)	-
6	Tilt alarm delay ON/OFF (**)	ON

#### \* Supervision Type

This switch should be left in OFF position. In this position the supervision messages are transmitted every 60 minutes (slow rate), to save battery power.

#### \*\* Tilt Alarm Delay Enable/Disable

Fifteen second pre-alarm delay enabled/disabled.

If the "tilt alarm delay" DIP switch is set to OFF position (no delay) the tilt pre-alarm DIP switch position is disregarded.

### 3.6 Buzzer Functions

The internal buzzer sounds, as shown in figure 4 and in the following situations:

- A. When someone is tampering / stops tampering with the unit.
- B. Whenever the internal DIP switch setting is changed.

## 4. PREPARATION FOR USE

### 4.1 MDT-122 Preparations for Use

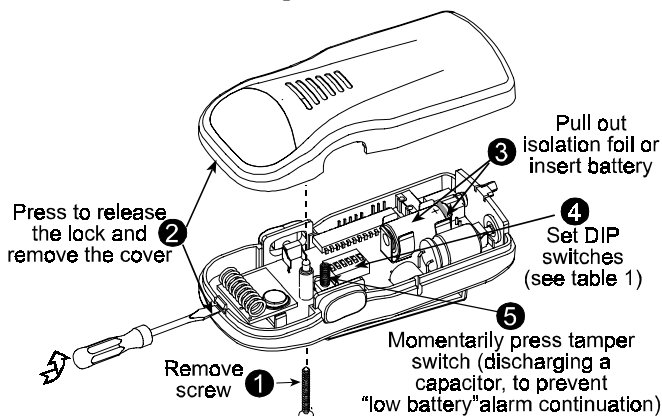

Figure 5 - Preparation for Use

### 4.2 Teaching the Target Receiver

It is recommended to use the MDT-122 with MCR-308 as a target receiver (for other receiver types, see section 1). Each of the four MDT-122 alarm types (Panic, Man-Down, Pull-Cord, Test) activates a different MCR-308 output, to provide any desired function, like sounding a siren or activating an automatic dialer (for delivering a prerecorded voice/digital message to predetermined addresses).

To provide the desired alarms, the target receiver must "learn" to identify the Man-down transmitter transmission. For the learning process, refer to the relevant receiver installation instructions document. If MCR-308 is used as a target receiver, refer to document DE3191, paragraphs 3-5 and 3-7 to 3-9.

### 4.3 Test

Simulate all the actions that are shown in figure 4 and verify that proper buzzer, LED and transmissions functions are performed.

## 5. NOTES AND WARNINGS

### 5.1 Product Limitations

Visonic wireless systems are very reliable and are tested to high standards. However, due to low transmitting power and limited range (required by FCC and other regulating authorities), there are some limitations to be considered:

- Receivers may be blocked by radio signals occurring on or near their operating frequencies, regardless of the digital code used.
- Wireless equipment should be tested regularly to determine whether there are sources of interference and to protect against faults.

### 5.2 Compliance with Standards

**WARNING!** Changes or modifications to this unit not expressly approved by the party responsible for compliance could void the user's authority to operate the equipment.

The 315MHz version complies with FCC Rules Part 15.

Operation is subject to two conditions: (1) This device may not cause harmful interference, and (2) this device must accept any interference that may be received or that may cause undesired operation.

The product has been tested and found to comply with the limits for class B digital device, pursuant to part 15 of the FCC Rules. These limits are designed to provide reasonable protection against harmful interference in a residential installation. This equipment generates, uses and can radiate radio frequency energy and, if not used in accordance with the instructions, may cause harmful interference to radio communications. However, there is no guarantee that the interference will not occur in a particular installation

### WARRANTY

Visonic Ltd. and/or its subsidiaries and its affiliates ("the Manufacturer") warrants its products hereinafter referred to as "the Product" or "Products" to be in conformance with its own plans and specifications and to be free of defects in materials and workmanship under normal use and service for a period of twelve months from the date of shipment by the Manufacturer. The Manufacturer's obligations shall be limited within the warranty period, at its option, to repair or replace the product or any part thereof. The Manufacturer shall not be responsible for dismantling and/or reinstallation charges. To exercise the warranty the product must be returned to the Manufacturer freight prepaid and insured.

**This warranty does not apply in the following cases:** improper installation, misuse, failure to follow installation and operating instructions, alteration, abuse, accident or tampering, and repair by anyone other than the Manufacturer.

This warranty is exclusive and expressly in lieu of all other warranties, obligations or liabilities, whether written, oral, express or implied, including any warranty of merchantability or fitness for a particular purpose, or otherwise. In no case shall the Manufacturer be liable to anyone for any consequential or incidental damages for breach of this warranty or any other warranties whatsoever, as aforesaid.

This warranty shall not be modified, varied or extended, and the Manufacturer does not authorize any person to act on its behalf in the modification, variation or extension of this warranty. This warranty shall apply to the Product only. All products, accessories or attachments of others used in conjunction with the Product, including batteries, shall be covered solely by their own warranty, if any. The Manufacturer shall not be liable for any damage or loss whatsoever, whether directly, indirectly, incidentally, consequentially or otherwise, caused by the malfunction of the Product due to products, accessories, or attachments of others, including batteries, used in conjunction with the Products.

The Manufacturer does not represent that its Product may not be compromised and/or circumvented, or that the Product will prevent any death, personal and/or bodily injury and/or damage to property resulting from burglary, robbery, fire or otherwise, or that the Product will in all cases provide adequate warning or protection. User understands that a properly installed and maintained alarm may only reduce the risk of events such as burglary, robbery, and fire without warning, but it is not insurance or a guarantee that such will not occur or that there will be no death, personal damage and/or damage to property as a result.

**The Manufacturer shall have no liability for any death, personal and/or bodily injury and/or damage to property or other loss whether direct, indirect, incidental, consequential or otherwise, based on a claim that the Product failed to function.** However, if the Manufacturer is held liable, whether directly or indirectly, for any loss or damage arising under this limited warranty or otherwise, regardless of cause or origin, the Manufacturer's maximum liability shall not in any case exceed the purchase price of the Product, which shall be fixed as liquidated damages and not as a penalty, and shall be the complete and exclusive remedy against the Manufacturer.

**Warning:** The user should follow the installation and operation instructions and among other things test the Product and the whole system at least once a week. For various reasons, including, but not limited to, changes in environmental conditions, electric or electronic disruptions and tampering, the Product may not perform as expected. The user is advised to take all necessary precautions for his /her safety and the protection of his/her property.

6/91



VISONIC LTD. (ISRAEL): P.O.B 22020 TEL-AVIV 61220 ISRAEL. PHONE: (972-3) 645-6789, FAX: (972-3) 645-6788  
VISONIC INC. (U.S.A.): 10 NORTHWOOD DRIVE, BLOOMFIELD CT. 06002-1911. PHONE: (860) 243-0833, (800) 223-0020 FAX: (860) 242-8094  
VISONIC LTD. (UK): FRASER ROAD, PRIORY BUSINESS PARK, BEDFORD MK44 3WH. PHONE: (0870) 730-0800 FAX: (0870) 730-0801  
Internet Web Site: www.visonic.com

©VISONIC LTD. 2001 MDT-122 , DE2292U (REV. 1, 1/2001).

